

## Low Dropout Positive Voltage Regulators

- 800mA
- 2.5V, 3.0V and 3.3V Output

The IMP37 series of Low Dropout (LDO) three-terminal voltage regulators feature guaranteed low dropout voltages at currents up to 0.8A. The IMP37 regulator family dropout voltage is guaranteed to be 0.95V or lower at 0.8A. At 100mA, the maximum dropout voltage is 0.8V. Compared with "1117" type LDOs, the IMP37 has a 20% lower dropout voltage.

Three fixed output voltages are offered: 2.5V, 3.0V and 3.3V. Output voltages are factory trimmed to within 1% of the nominal value.

In addition to low dropout voltages, the IMP37 family features greatly reduced quiescent operating current. The 75 $\mu$ A maximum specification represents an over 100 times improvement over competitive devices.

Devices are short circuit protected, and a thermal protection circuit shuts the regulator off should the junction temperature exceed 165°C.

The IMP37 is available in low-profile plastic SOT-223 and TO-263 packages and are pin compatible with fixed "1117" devices.

### Key Features

- ◆ Low Dropout Voltage
  - 0.8V maximum at 100mA
  - 0.95V maximum at 800mA
  - 20% lower dropout voltage than "1117" LDO regulators
- ◆ Guaranteed Low Dropout Voltage at Multiple Current Levels
- ◆ 1% Trimmed 2.5V, 3.0V and 3.3V Outputs
- ◆ Reduced Quiescent Current: 75 $\mu$ A Maximum
- ◆ Short Circuit and Thermal Protection
- ◆ Space Saving SOT-223 Surface Mount Package
- ◆ "1117" Pin Compatible

### Applications

- ◆ High-efficiency linear power supplies
- ◆ Post regulator for switching supplies
- ◆ 5V to 3.3V linear regulators
- ◆ USB hubs
- ◆ Battery chargers
- ◆ Routers, ISDN/DSL modems

### Block Diagram

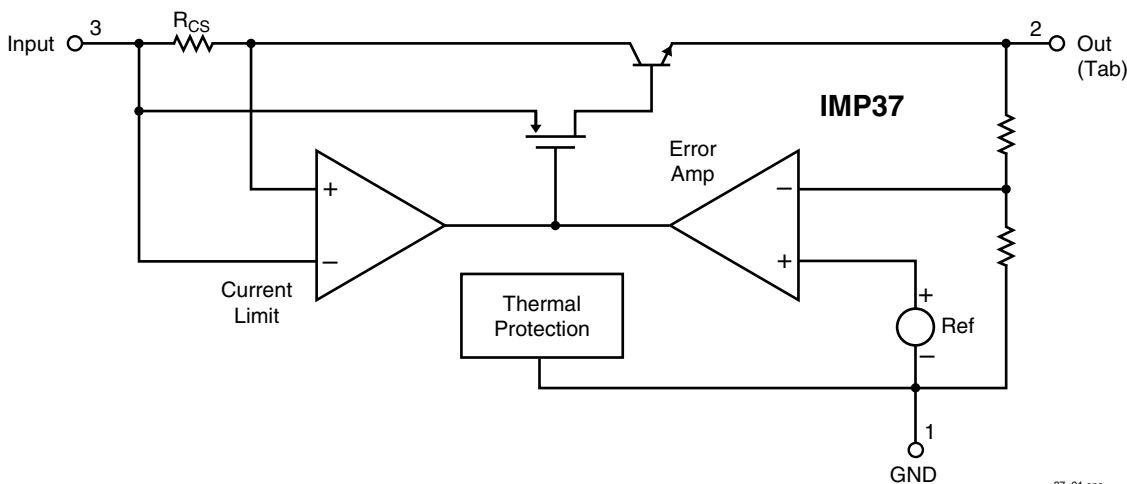

37\_01.eps

## Pin Configuration

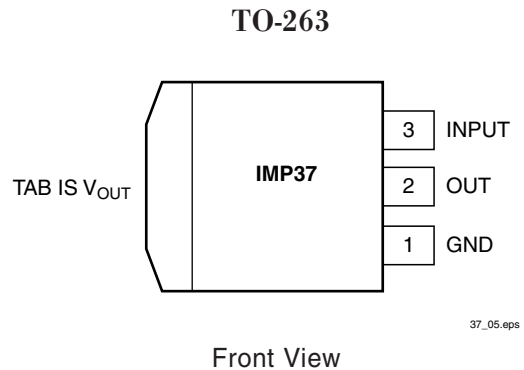
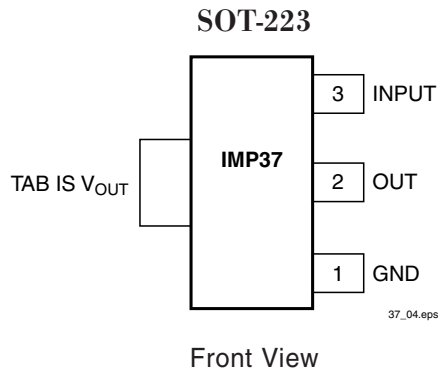

## Pin Descriptions

Pin Number	Name	Function
1	GND	Ground Pin
2	OUT	Output Voltage
3	INPUT	Input Voltage
TAB	TAB	Output Voltage

37\_Table03.eps

## Package Marking Code

Part Number	Package	Device Marking
IMP37-25JST	SOT-223	3725
IMP37-30JST	SOT-223	3730
IMP37-33JST	SOT-223	3733
IMP37-25JCM	TO-263	3725JCM
IMP37-30JCM	TO-263	3730JCM
IMP37-33JCM	TO-263	3733JCM

37\_Table05.eps

## Ordering Information

Output Options			Part Ordering Number	
Voltage	Maximum Quiescent Current	Dropout Voltage at 800mA	SOT-223 Package	TO-263 Package
2.5V	75 $\mu$ A	0.95V	IMP37-25JST	IMP37-25JCM
3.0V	75 $\mu$ A	0.95V	IMP37-30JST	IMP37-30JCM
3.3V	75 $\mu$ A	0.95V	IMP37-33JST	IMP37-33JCM

37\_106.eps

Note: Tape and reel shipping is available for the SOT-223 and TO-263 packages. Append the TAPE AND REEL designation "/T" to the ordering part number for tape and reel devices. For example, the IMP37-25JST/T is a 2.5V SOT-223 packaged device shipped in reels.

## Absolute Maximum Ratings

Input Voltage ..... 7V  
 Operating Junction Temperature ..... 0°C to 150°C

Storage Temperature Range ..... -65°C to +150°C  
 Lead Temperature (Soldering) ..... 300°C for 10 seconds

*These are stress ratings only and functional operation is not implied. Exposure to absolute maximum ratings for prolonged time periods may affect device reliability. All voltages are with respect to ground.*

## Electrical Characteristics

Specifications apply over the junction operating temperature range of  $T_J = 0^\circ\text{C}$  to  $+125^\circ\text{C}$  unless otherwise noted.

Parameter	Symbol	Suffix	Conditions	Min	Typ	Max	Units
Output Voltage	$V_{OUT}$	-25	$I_{OUT} = 10\text{mA}$ , $V_{IN} = 4.85\text{V}$ , $T_J = 25^\circ\text{C}$	2.475	2.5	2.525	V
			$10\text{mA} \leq I_{OUT} \leq I_{MAX}$ , $4.25\text{V} \leq V_{IN} \leq 5.5\text{V}$	2.45	2.5	2.55	
		-30	$I_{OUT} = 10\text{mA}$ , $V_{IN} = 5\text{V}$ , $T_J = 25^\circ\text{C}$	2.97	3.00	3.03	
			$10\text{mA} \leq I_{OUT} \leq I_{MAX}$ , $4.75\text{V} \leq V_{IN} \leq 5.5\text{V}$	2.94	3.00	3.06	
		-33	$I_{OUT} = 10\text{mA}$ , $V_{IN} = 5\text{V}$ , $T_J = 25^\circ\text{C}$	3.267	3.30	3.333	
			$10\text{mA} \leq I_{OUT} \leq I_{MAX}$ , $4.75\text{V} \leq V_{IN} \leq 5.5\text{V}$	3.235	3.30	3.365	
Line Regulation (Note 1)		-25	$I_{OUT} = 10\text{mA}$ , $4.25\text{V} \leq (V_{IN}) \leq 5.5\text{V}$		12	19	mV
		-30	$I_{OUT} = 10\text{mA}$ , $4.5\text{V} \leq V_{IN} \leq 5.5\text{V}$		12	19	
		-33	$I_{OUT} = 10\text{mA}$ , $4.5\text{V} \leq V_{IN} \leq 5.5\text{V}$		12	19	
Line Regulation (Note 1)		-25	$I_{OUT} = 10\text{mA}$ , $4.25\text{V} \leq (V_{IN}) \leq 5.5\text{V}$ , $T_A = 25^\circ\text{C}$		2.8	4.3	mV
		-30	$I_{OUT} = 10\text{mA}$ , $4.5\text{V} \leq V_{IN} \leq 5.5\text{V}$ , $T_A = 25^\circ\text{C}$		2.8	4.3	
		-33	$I_{OUT} = 10\text{mA}$ , $4.5\text{V} \leq V_{IN} \leq 5.5\text{V}$ , $T_A = 25^\circ\text{C}$		2.8	4.3	
Load Regulation (Note 1)		-25	$V_{IN} = 4.25\text{V}$ , $5\text{mA} \leq I_{OUT} \leq 800\text{mA}$		25	30	mV
		-30	$V_{IN} = 4.75\text{V}$ , $5\text{mA} \leq I_{OUT} \leq 800\text{mA}$		25	30	
		-33	$V_{IN} = 4.75\text{V}$ , $5\text{mA} \leq I_{OUT} \leq 800\text{mA}$		25	30	
Dropout Voltage (Note 2)		-xx	$I_{OUT} = 100\text{mA}$			0.8	V
			$I_{OUT} = 800\text{mA}$			0.95	
Current Limit	$I_{OUT(MAX)}$	-xx	$T_J = 25^\circ\text{C}$	800	950	1200	mA
Minimum Load Current		-xx				5.0	mA
Quiescent Current	$I_Q$	-xx	$V_{IN} \leq 6\text{V}$		36	75	$\mu\text{A}$
Thermal Regulation			$T_A = 25^\circ\text{C}$ , 30ms Pulse		0.01	0.1	%/W
Ripple Rejection			$f_{RIPPLE} = 120\text{Hz}$ , $V_{IN} = 5\text{V}$ , $T_A = 25^\circ\text{C}$ $V_{RIPPLE} = 1\text{Vp-p}$ , $I_{LOAD} = 10\text{mA}$	51	54		dB
Temperature Stability					0.5		%
Long Term Stability			$T_A = 125^\circ\text{C}$ , 1000 Hrs		0.3		%
RMS Output Noise			(% of $V_{OUT}$ ), $10\text{Hz} \leq f \leq 10\text{kHz}$ , $T_J = 25^\circ\text{C}$		0.003		%
Thermal Resistance			Junction-to-Case at TAB (TO-223)		15		$^\circ\text{C/W}$
			Junction-to-Case at TAB (TO-263)		10		

Notes: 1. See thermal regulation specification for changes in output voltage due to heating effects. Load regulation and line regulation are measured with low duty cycle pulse testing to maintain a constant junction temperature.

2. Dropout voltage is specified over the full output current range. Dropout voltage is defined as the minimum input/output differential output current.

3. Minimum load current is defined as the minimum output current required to maintain regulation.

## Application Information

The IMP37 voltage regulator ICs offer self-protection features which include short-circuit current protection and automatic thermal shutdown (for junction temperature above 165°C).

### Circuit Stability

Like all regulators, an output filter capacitor is required for circuit stability. Besides smoothing the output, the output capacitor “completes” the regulator’s frequency compensation. The ESR of the output capacitor should be less than 0.5Ω. Low ESR capacitors are preferred.

Table 1 shows recommended minimum capacitance values for both aluminum and tantalum capacitors. Larger values of output capacitance do not cause stability problems.

**Table 1. Recommended Output Bypass Capacitors**

Output Bypass Capacitor (ESR < 0.5Ω)
10μF Tantalum, 100μF Aluminum

An input bypass capacitor is recommended. A 10μF or larger tantalum capacitor is suitable for most applications.

### Thermal Management

The maximum operating junction temperature for the IMP37 devices is 150°C. The junction temperature can be calculated when the power dissipation and ambient temperature are known with this equation:  $T_J = T_A + (P_D \times \Theta_{JA})$ .

The thermal resistance from junction-to-ambient ( $\Theta_{JA}$ ) is the sum of the three thermal resistances:

$$\Theta_{JA} = \Theta_{JT} + \Theta_{TS} + \Theta_{SA}$$

Where  $\Theta_{JT}$  = Junction-to-Tab thermal resistance

$\Theta_{TS}$  = Tab-to-Heat Sink thermal resistance

$\Theta_{SA}$  = Heat Sink-to-Air thermal resistance

**Table 2. Thermal Resistance of Packages**

Package Type	Thermal Resistance
	Junction to Tab, $\Theta_{JT}$
SOT-223	15°C/W
TO-263	10°C/W

The IMP37 series devices have thermal limiting circuitry to protect the device from over current. For continuous operation, the maximum junction temperature rating must not be exceeded.

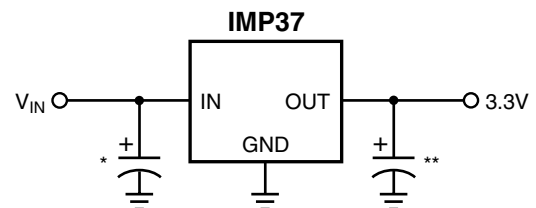

\* Min. 15μF Tantalum or 100μF Aluminum. Capacitor May Be Increased Without Limit.

\*\* 10μF Tantalum or 100μF Aluminum

37\_02.eps

*Figure 1. Fixed 3.3V Regulator*

## Package Dimensions

### Plastic SOT-223 (4-Pin)

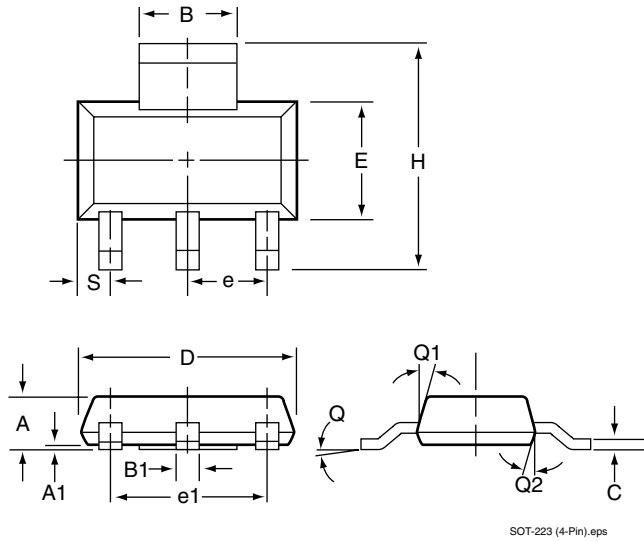

### TO-263 (3-Pin)

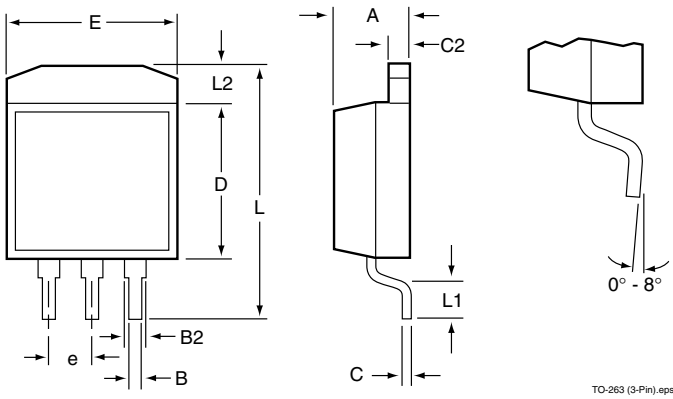

	Inches		Millimeters	
	Min	Max	Min	Max
<b>Plastic SOT-223 (4-Pin)*</b>				
A	0.067	0.060	1.70	1.50
A1	0.004	0.0008	0.10	0.02
B	0.124	0.116	3.15	2.95
B1	0.033	0.026	0.85	0.65
C	0.014	0.010	0.35	0.25
D	0.264	0.248	6.70	6.30
e	0.0905 NOM		2.30 NOM	
e1	0.181 NOM		4.50 NOM	
E	0.146	0.130	3.70	3.30
h	0.287	0.264	7.30	6.70
S	0.041	0.033	1.05	0.85
t	0.051	0.043	1.30	1.10
Q	10° MAX		10° MAX	
Q1	16°	10°	16°	10°
Q2	16°	10°	16°	10°
<b>TO-263 (3-Pin)**</b>				
A	0.160	0.190		
B	0.020	0.039		
B2	0.045	0.055		
C	0.018	0.029		
C2	0.045	0.055		
D	0.340	0.380		
E	0.380	0.405		
e	0.100 BSC			
L	0.575	0.625		
L1	0.090	0.110		
L2	—	0.055		

\* JEDEC Drawing TO-261AA

\*\* JEDEC Drawing TO-263AA

♦ Add /T to Part Number for Tape and Reel.

37\_Table04.eps



IMP, Inc.  
Corporate Headquarters  
2830 N. First Street  
San Jose, CA 95134-2071  
Tel: 408-432-9100  
Tel: 800-438-3722  
Fax: 408-434-0335  
e-mail: [info@impinc.com](mailto:info@impinc.com)  
<http://www.impweb.com>

The IMP logo is a registered trademark of IMP, Inc.  
All other company and product names are trademarks of their respective owners.

© 1999 IMP, Inc.  
Printed in USA  
Publication #: 8002  
Revision: C  
Issue Date: 07/22/99  
Type: Preliminary